

# Trail JUNIOR OPEN + Qualifikation

Pattern - Q jun. Trail - Set 8 - #1 - LK 1/2

## BEWERB 1

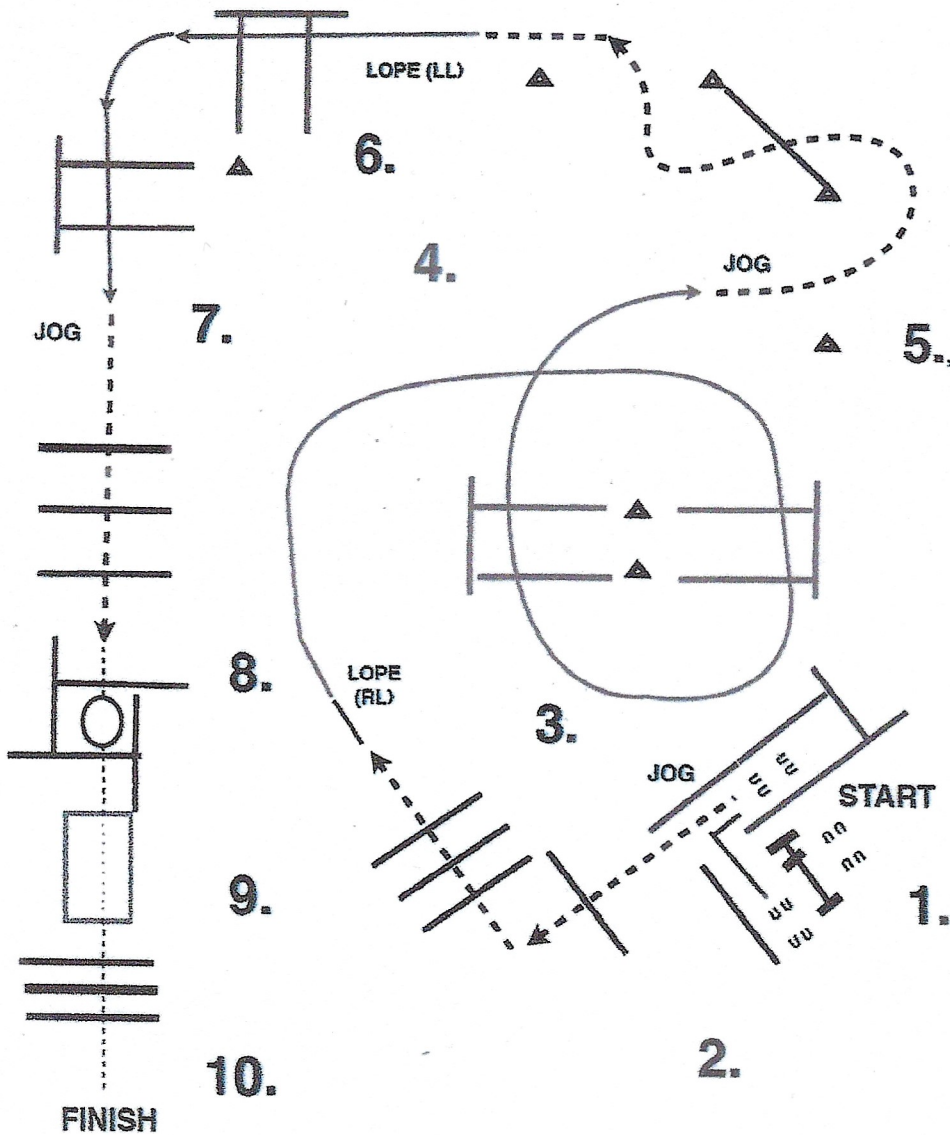

- (1) Tor (linke Hand)
- (2) Back up, Jog out
- (3) Jog over
- (4) Lope over (Rechtsgalopp)
- (5) Jog Slalom, Jog over
- (6) Lope over (Linksgalopp)
- (7) Jog over
- (8) Walk in, 360° Turn (rechts oder links), Walk out
- (9) Brücke
- (10) Walk over

TRAIL COURSES DESIGNED BY  
TIM KIMURA - ©

# Trail YOUTH + Qualifikation

Pattern - Q jun. Trail - Set B - #2 - LK 1/2

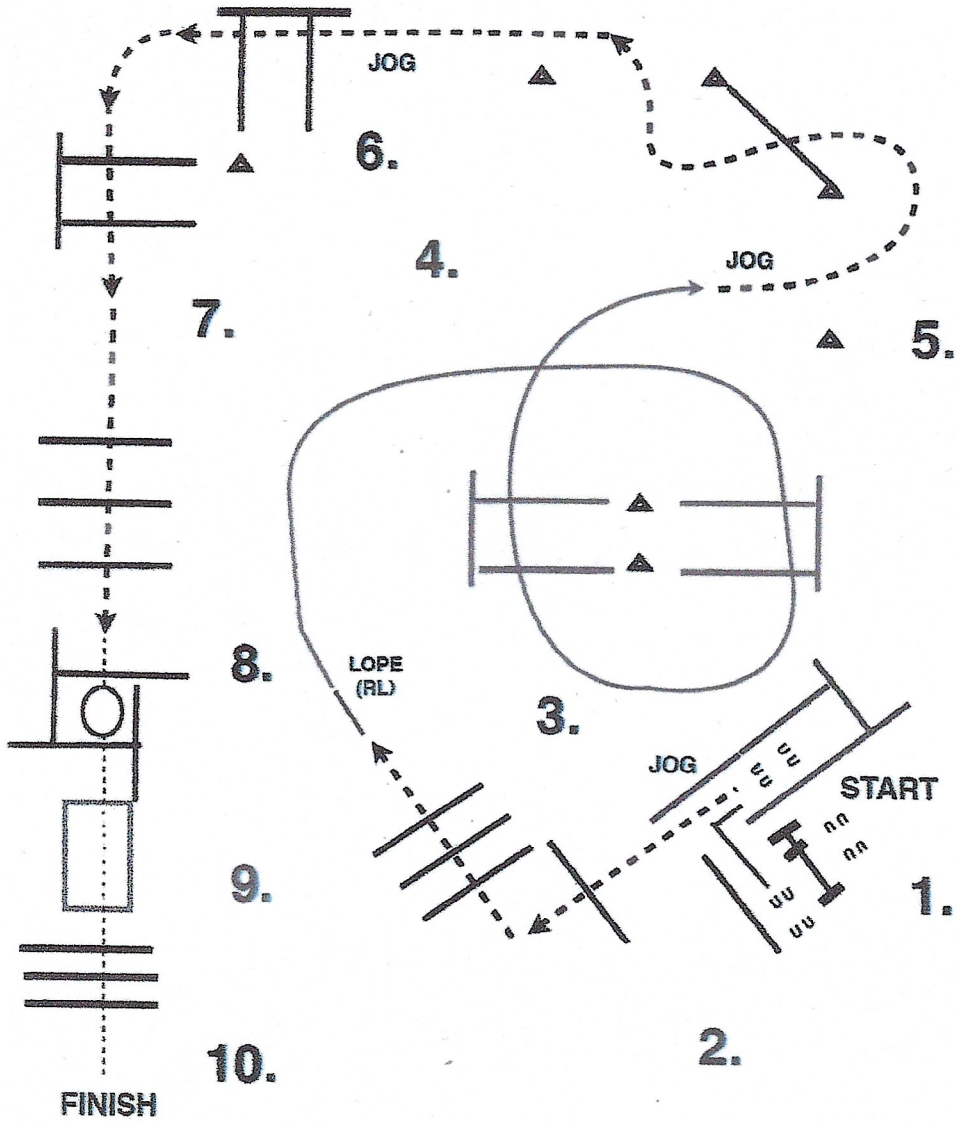

- (1) Tor (linke Hand)
- (2) Back up, Jog out
- (3) Jog over
- (4) Lope over (Rechtsgalopp)
- (5) Jog Slalom, Jog over
- (6) Jog over
- (7) Jog over
- (8) Walk in, 360° Turn (rechts oder links), Walk out
- (9) Brücke
- (10) Walk over

TRAIL COURSES DESIGNED BY  
TIM KIMURA ©



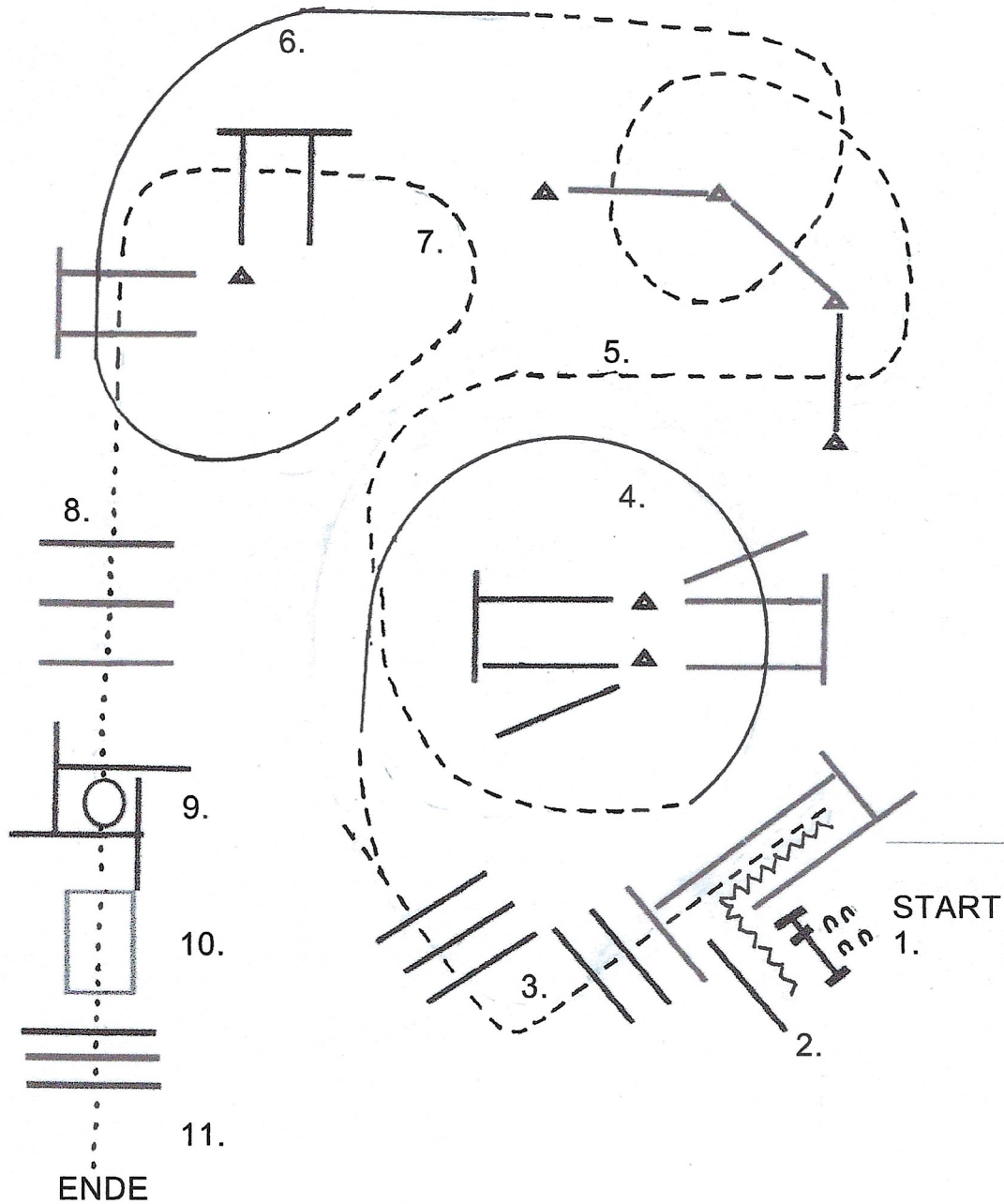

1. Tor linke Hand (Gate left hand)
2. Rückwärts (Back Up)
3. Trab über Stangen (Jog over)
4. Rechtsgalopp über Stangen (Lope over, right hand)
5. Trab über Stangen (Jog over)
6. Linksgalopp über Stangen (Lope over, left hand)
7. Trab über Stangen (Jog over)
8. Schritt über Stangen (Walk over)
9. Schritt in Box, 360° (Walk into Box, 360°)
10. Schritt über Brücke (Walk over bridge)
11. Schritt über Stangen (Walk over)

# Trail SENIOR OPEN + Qualifikation

Pattern - Q sen. Trail - Set B - #3 - LK 1/2 A

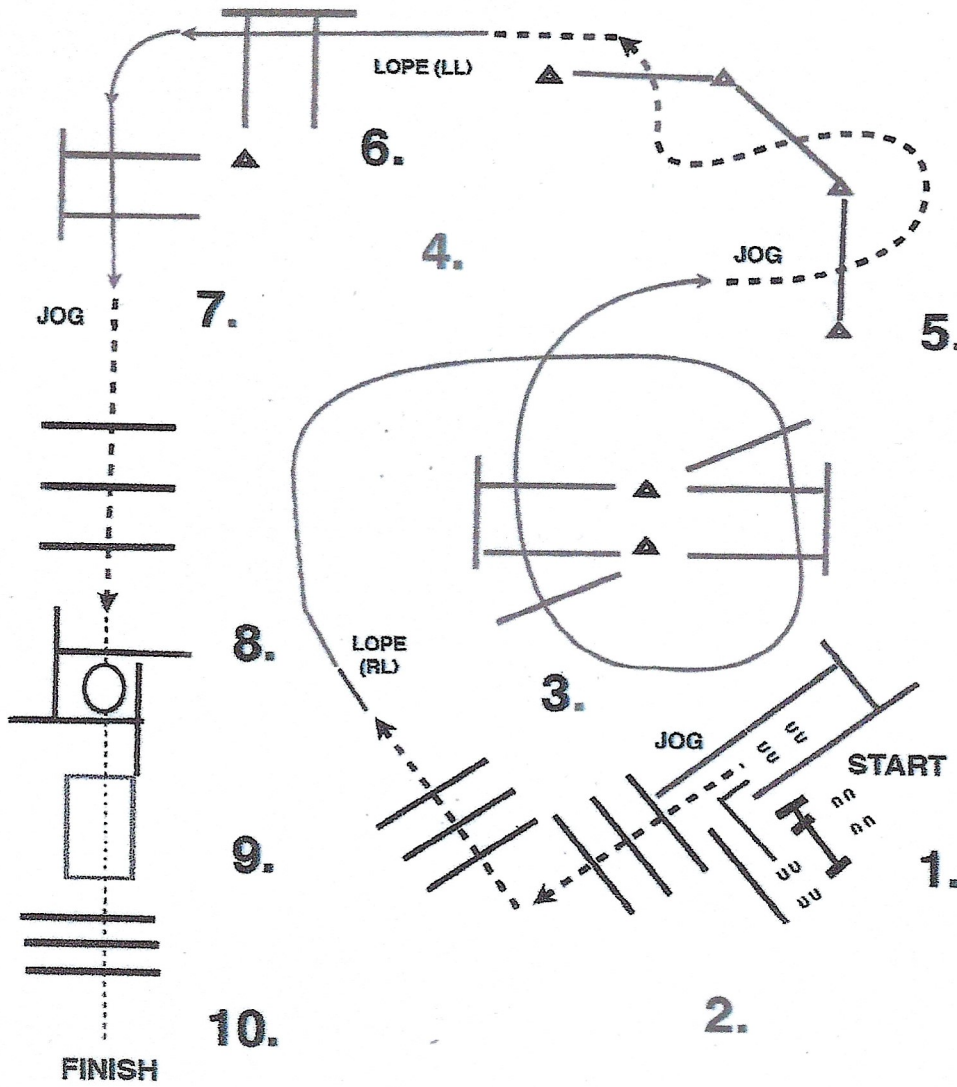

- (1) Tor (linke Hand)
- (2) Back Up, Jog out
- (3) Jog over
- (4) Lope over (Rechtsgalopp)
- (5) Jog Slalom, Jog over
- (6) Lope over (Linksgalopp)
- (7) Jog over
- (8) Walk in, 360° Turn (rechts oder links), Walk out
- (9) bridge
- (10) Walk over

TRAIL COURSES DESIGNED BY  
TIM KIMURA ©

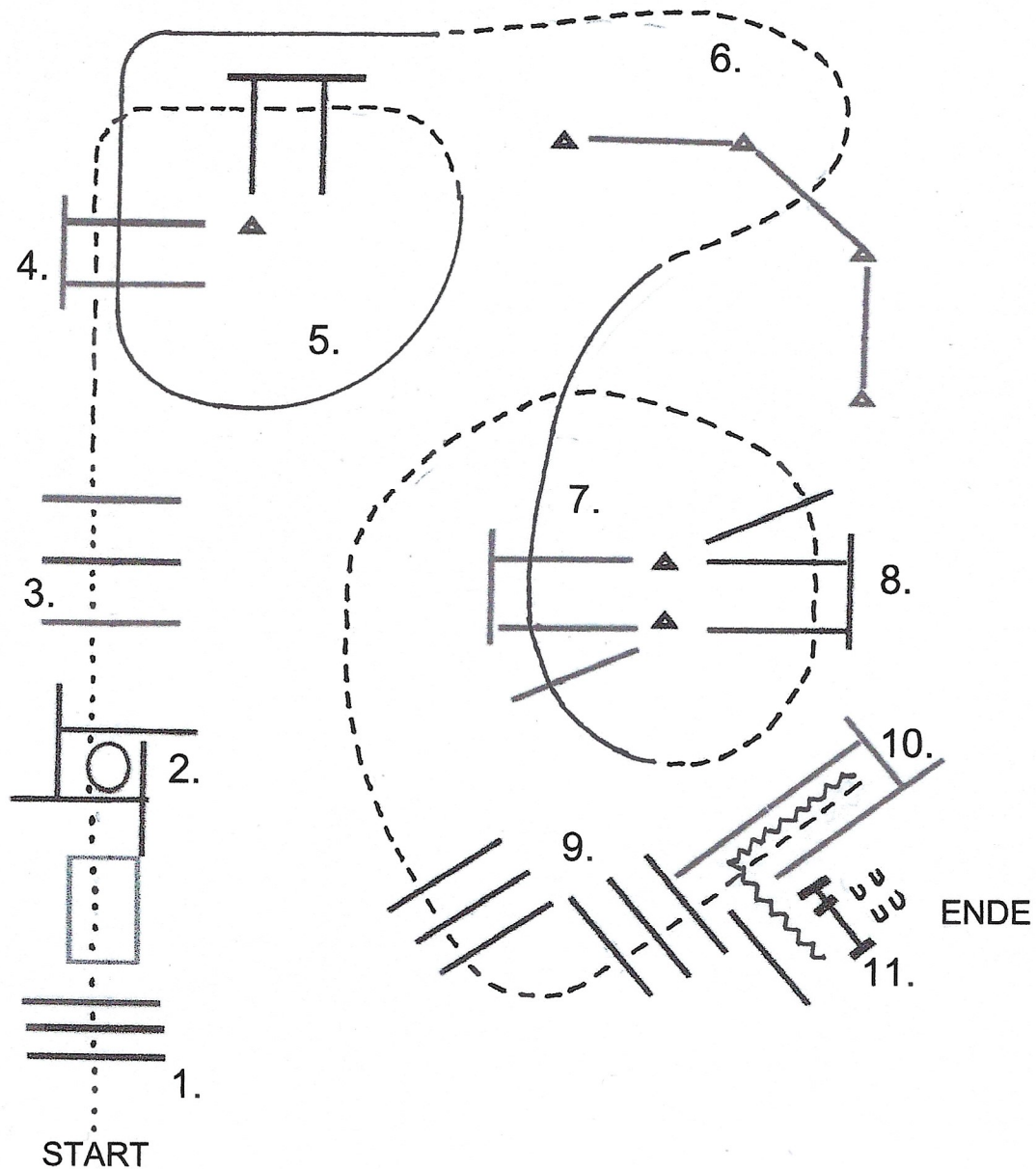

1. Schritt über Stangen und Brücke (Walk over pole and bridge)
2. Schritt in Box, Drehung 360°, Schritt hinaus (Walk into box, turn 360°, walk out)
3. Schritt über Stangen (Walk over)
4. Trab über Stangen (Jog over)
5. Rechtsgalopp über Stangen (Lope over, right hand)
6. Trab über Stange (Jog over)
7. Linksgalopp über Stangen (Lope over, left hand)
8. Trab über Stangen (Jog over)
9. Trab über Stangen (Jog over)
10. Rückwärts (Back Up)
11. Tor, rechte Hand (Gate, left hand)

# Trail AMATEUR

# BEWERB 15

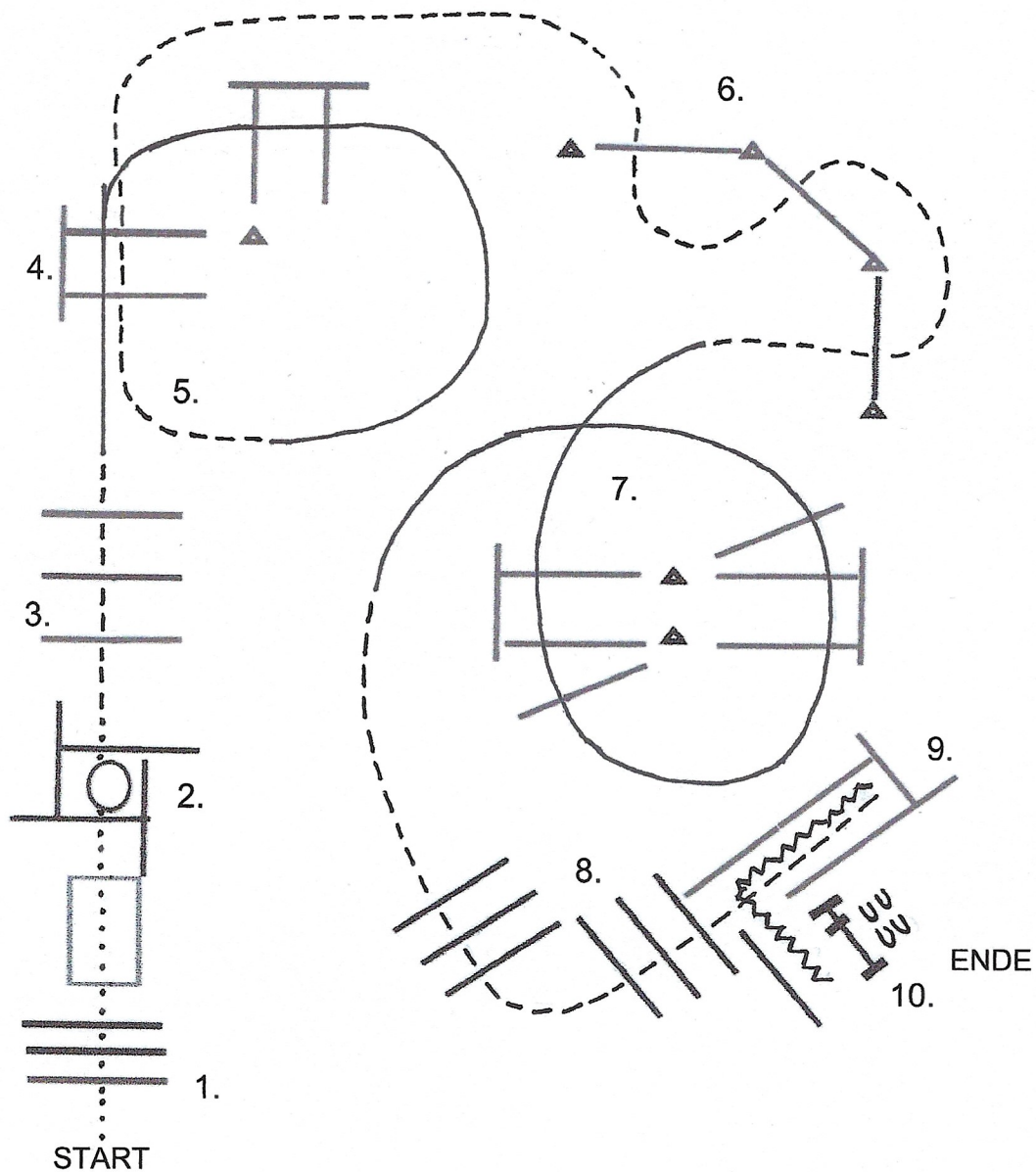

1. Schritt über Stangen und Brücke (Walk over pole and bridge)
2. Schritt in Box, Drehung 360° rechts, Schritt hinaus (Walk into box, turn 360° right, walk out)
3. Trab über Stangen (Jog over)
4. Rechtsgalopp über Stangen (Lope over, right hand)
5. Trab über Stangen (Jog over)
6. Trab über Stangen (Jog over)
7. Linksgalopp über Stangen (Lope over, left hand)
8. Trab über Stangen (Jog over)
9. Rückwärts (Back Up)
10. Tor, rechte Hand (Gate, right hand)

Trail OPEN

Trail OPEN - ÖM VORLAUF

BEWERB 16

BEWERB 17

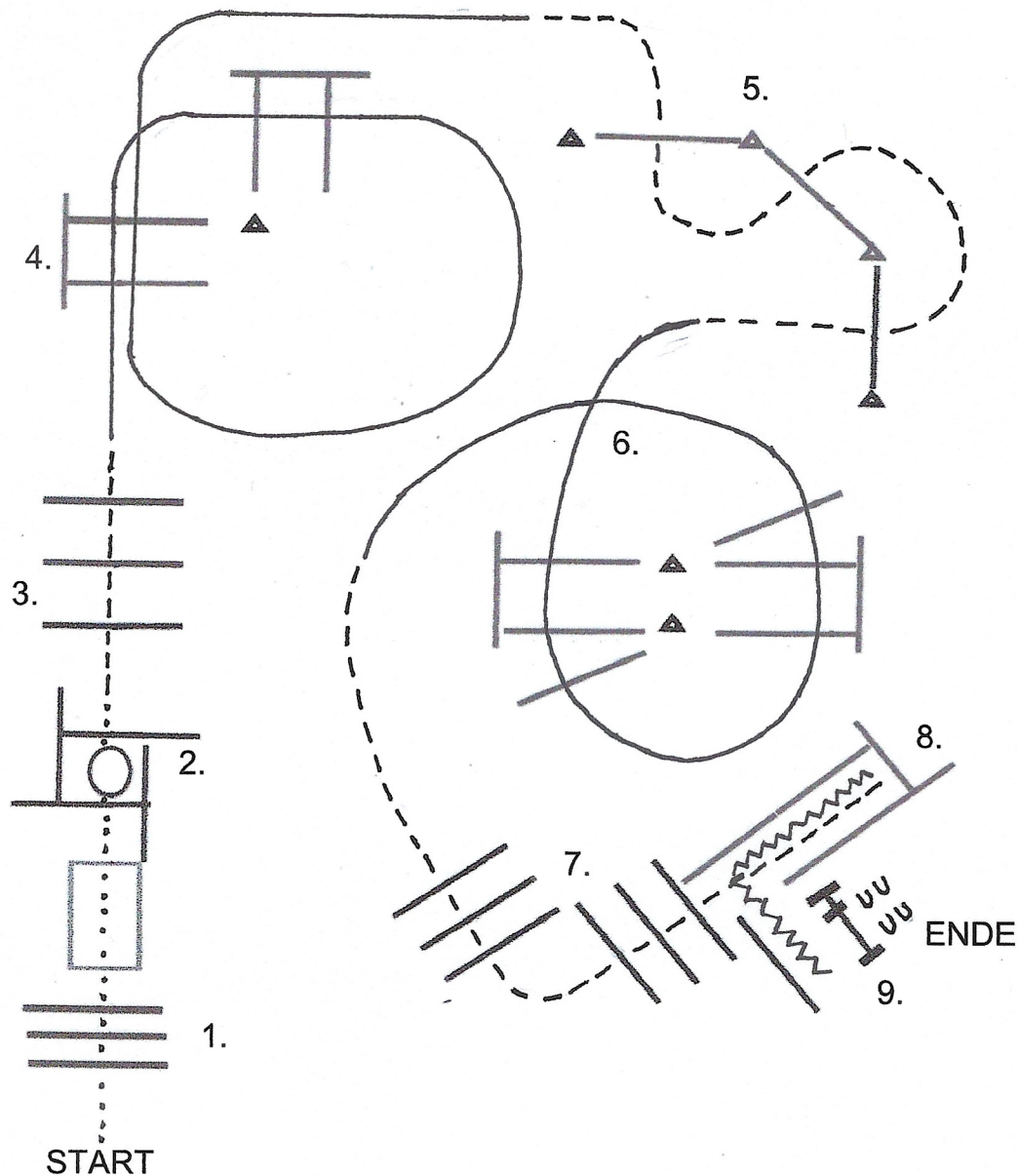

1. Schritt über Stangen und Brücke (Walk over pole and bridge)
2. Schritt in Box, Drehung 2x links, Schritt hinaus (Walk into box, turn left 2x , walk out)
3. Trab über Stangen (Jog over)
4. Rechtsgalopp über Stangen (Lope over, right hand)
5. Trab über Stangen (Jog over)
6. Linksgalopp über Stangen (Lope over, left hand)
7. Trab über Stangen (Jog over)
8. Rückwärts (Back Up)
9. Tor, rechte Hand (Gate, right hand)

# Trail FÜHRZÜGEL (4-8 Jahre)

# BEWERB 18

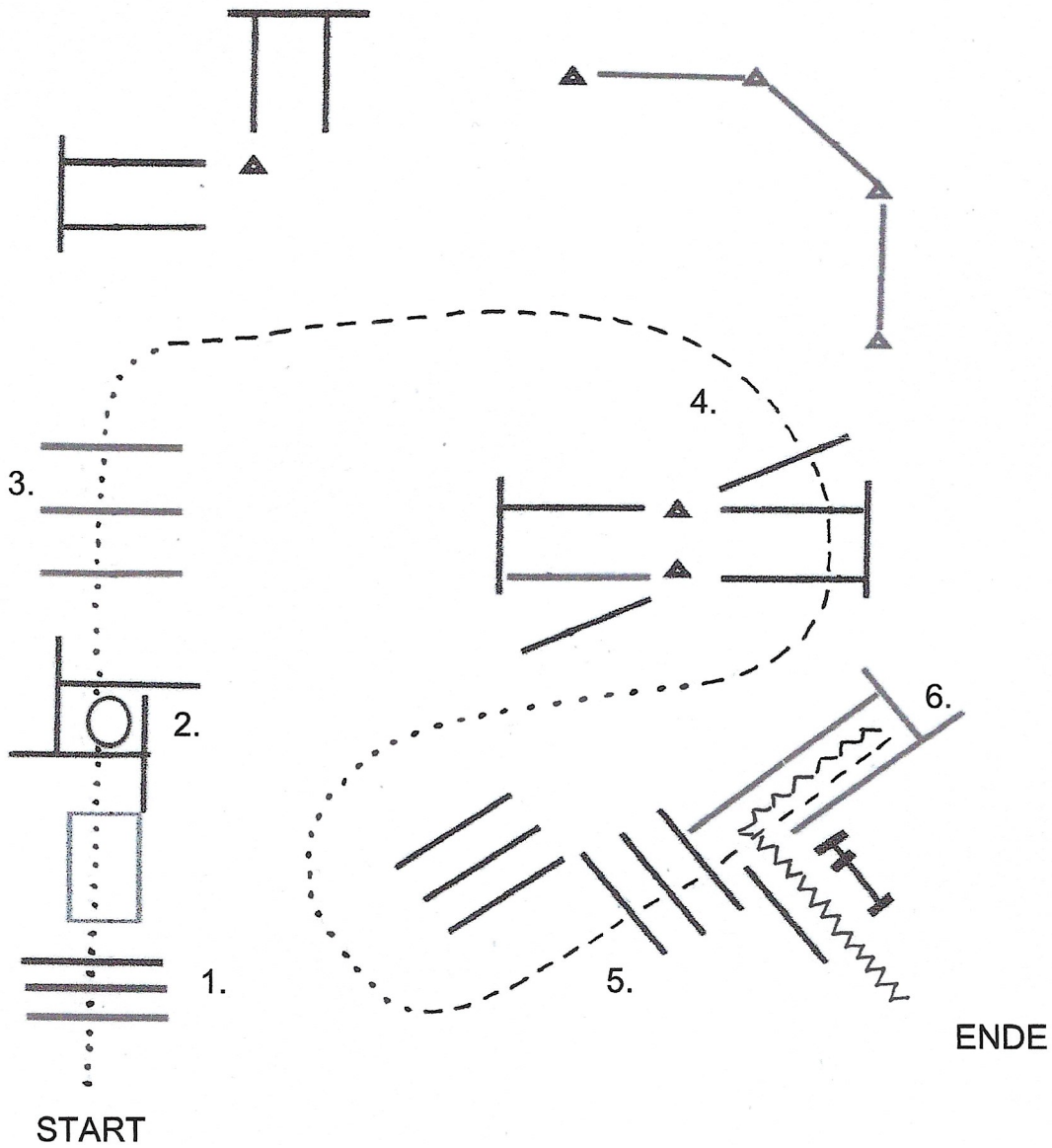

1. Schritt über Stangen und Brücke (Walk over pole and bridge)
2. Schritt in Box, Drehung 360° (Walk into box, turn 360°)
3. Schritt über Stangen (Walk over)
4. Trab über Stangen, Schritt (Jog over, walk)
5. Trab über Stangen (Jog over)
6. Rückwärts (Back Up)



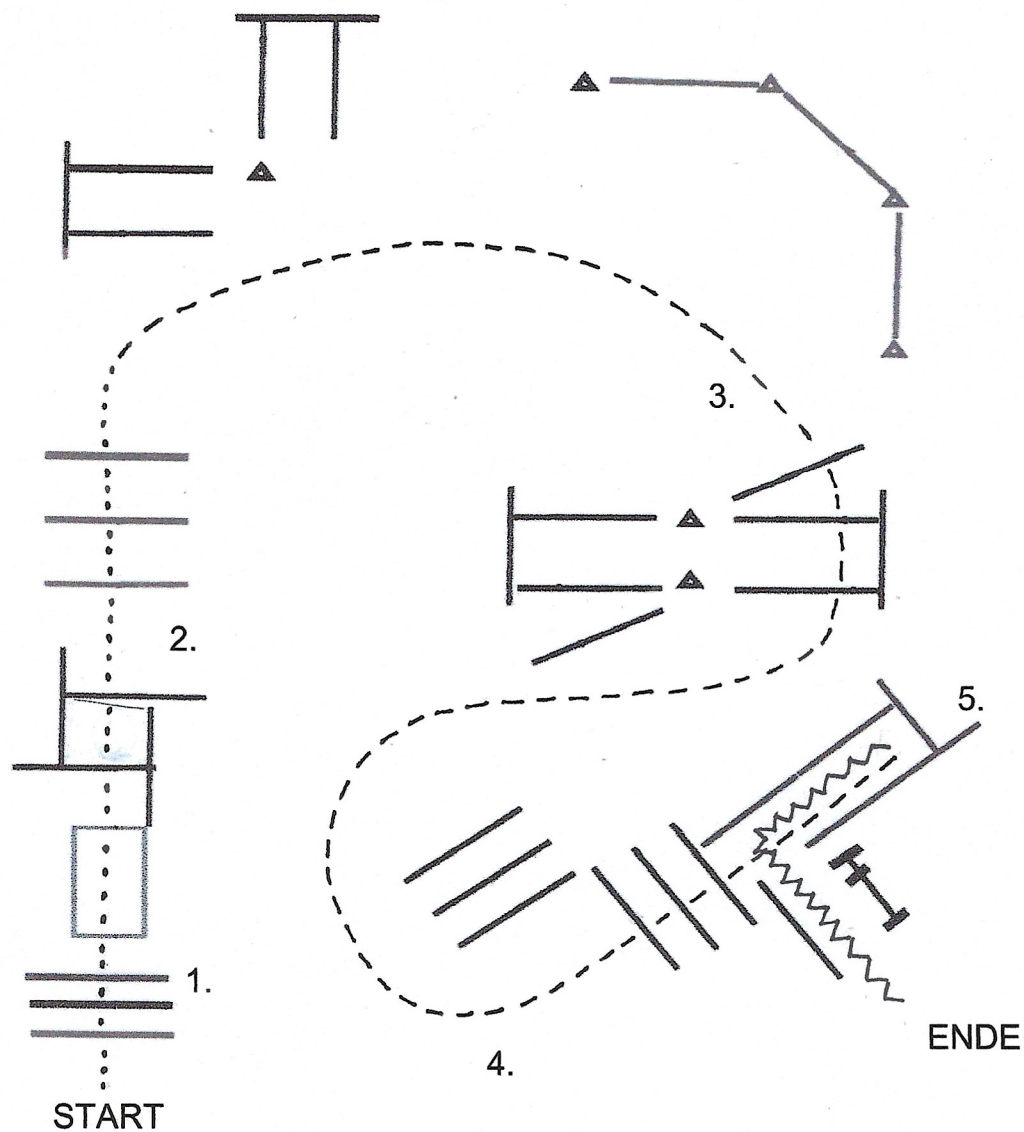

1. Schritt über Stangen, Brücke und Box (Walk over pole, bridge and box)
2. Schritt über Stangen (Walk over)
3. Trab über Stangen (Jog over)
4. Trab über Stangen (Jog over)
5. Rückwärts (Back Up)

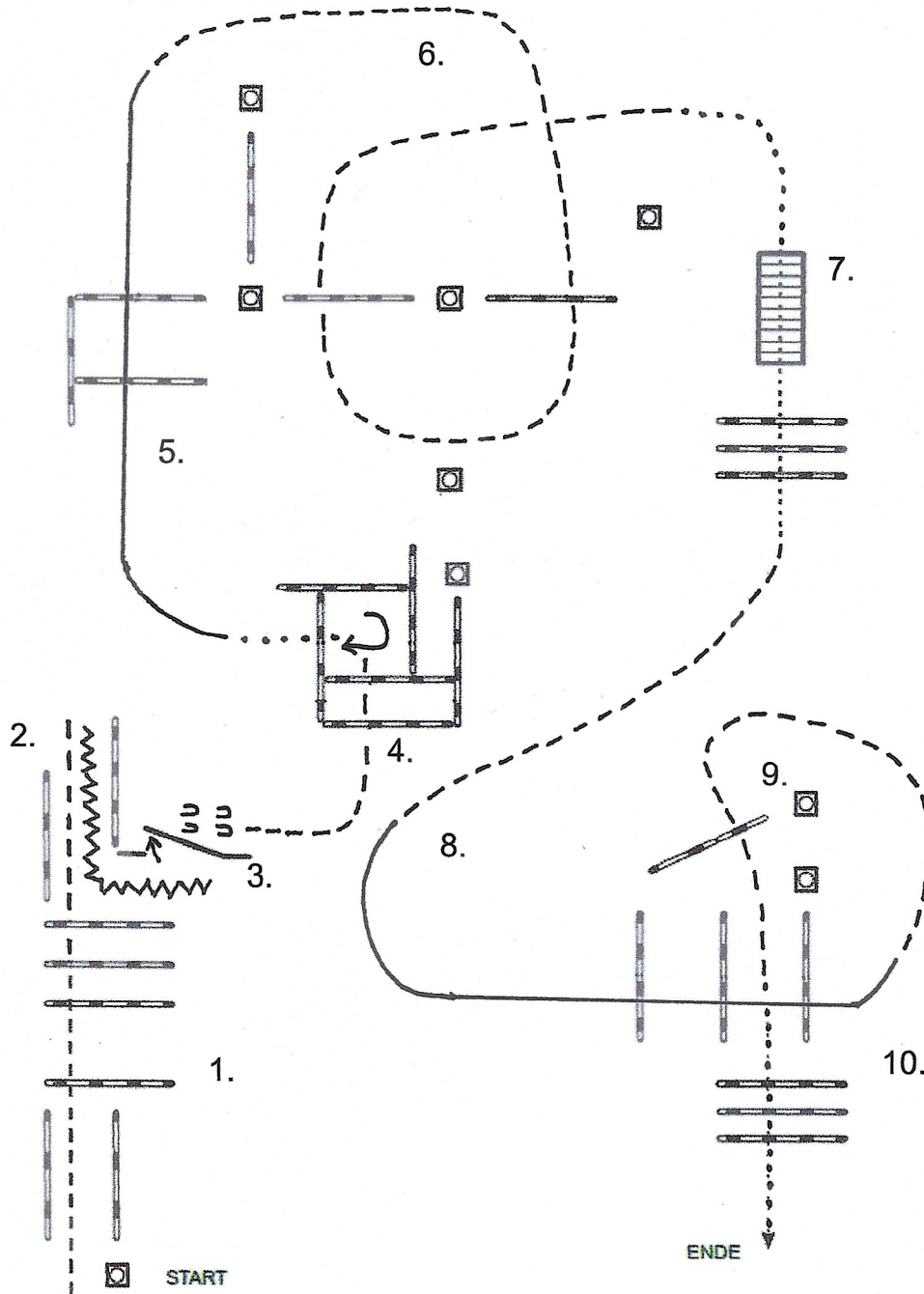

1. Trab über Stangen, stopp (Jog over, stop)
2. Rückwärts (Back Up)
3. Tor, rechte Hand (Gate, right hand)
4. Trab über Stangen in Box, 3/4 Drehung rechts, Schritt hinaus (Jog over into box, 3/4 turn right, walk out)
5. Rechtsgalopp über Stangen (Lope over, right hand)
6. Trab über Stangen (Jog over)
7. Schritt über Brücke und Stangen (Walk over bridge and pole)
8. Trab, Linksgalopp über Stangen (Jog, Lope over left hand)
9. Trab über Stange (Jog over)
10. Schritt über Stangen (Walk over)

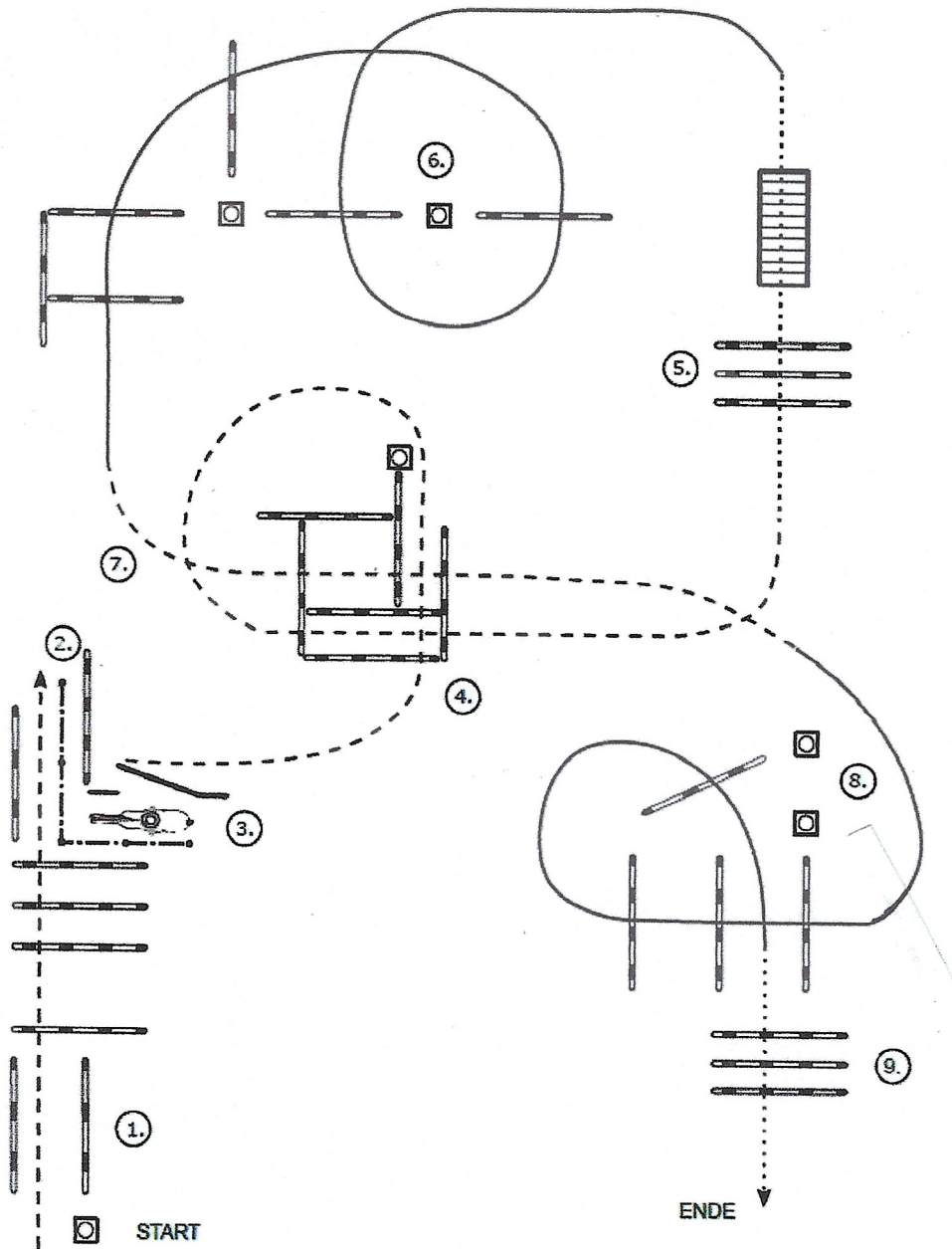

- (1) Jog over, Stop
- (2) Back up
- (3) Tor (rechte Hand), Jog out
- (4) Jog over
- (5) Stop/Übergang zum Walk, Walk over, Brücke
- (6) Lope over (Linksgalopp)
- (7) Jog over
- (8) Lope over (Rechtsgalopp)
- (9) Lope in, Stop/Übergang zum Walk, Walk over

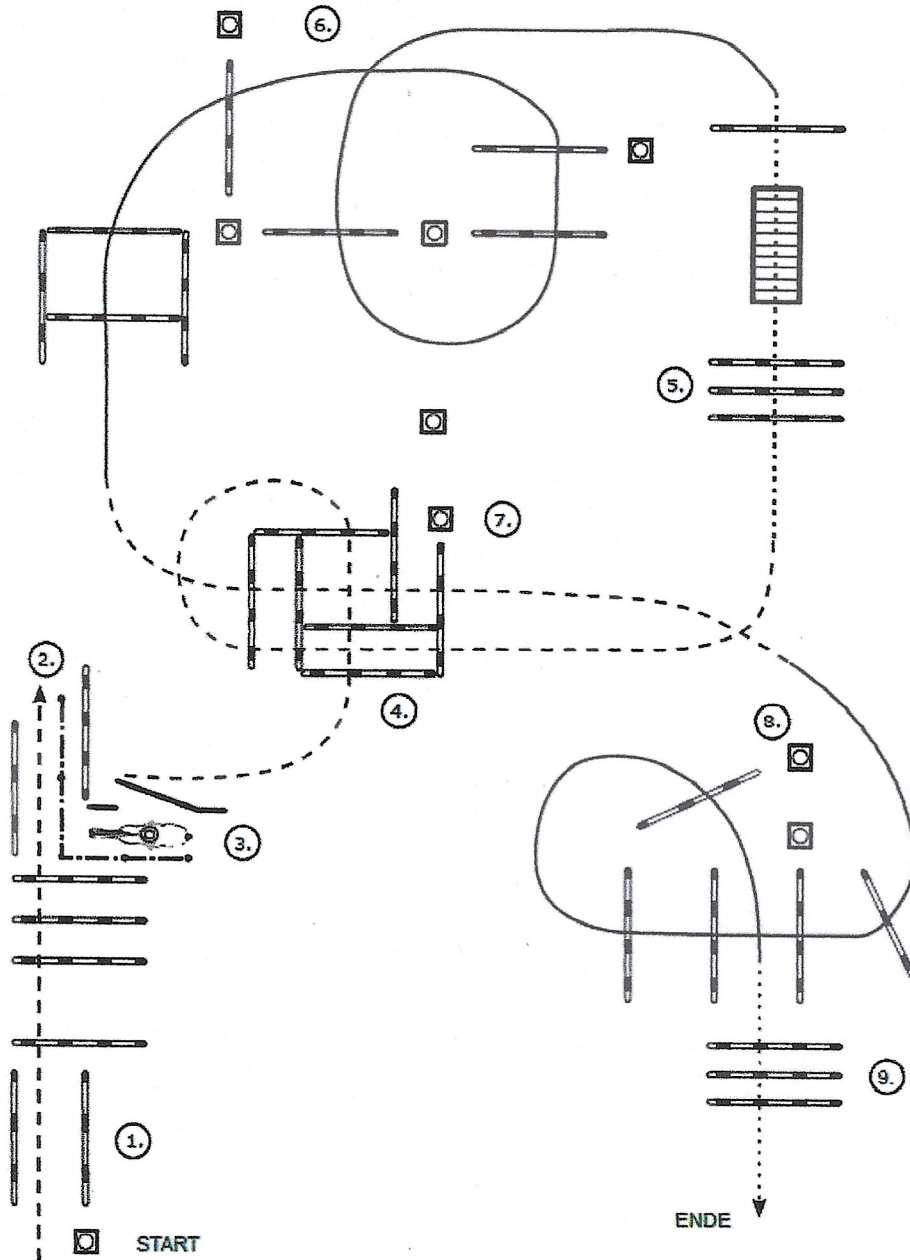

- (1) Jog over, Stop
- (2) Back up
- (3) Tor (rechte Hand), Jog out
- (4) Jog over
- (5) Stop/Übergang zum Walk, Walk over, Brücke, Walk over
- (6) Lope over (Linksgalopp)
- (7) Jog over
- (8) Lope over (Rechtsgalopp)
- (9) Lope in, Stop/Übergang zum Walk, Walk over

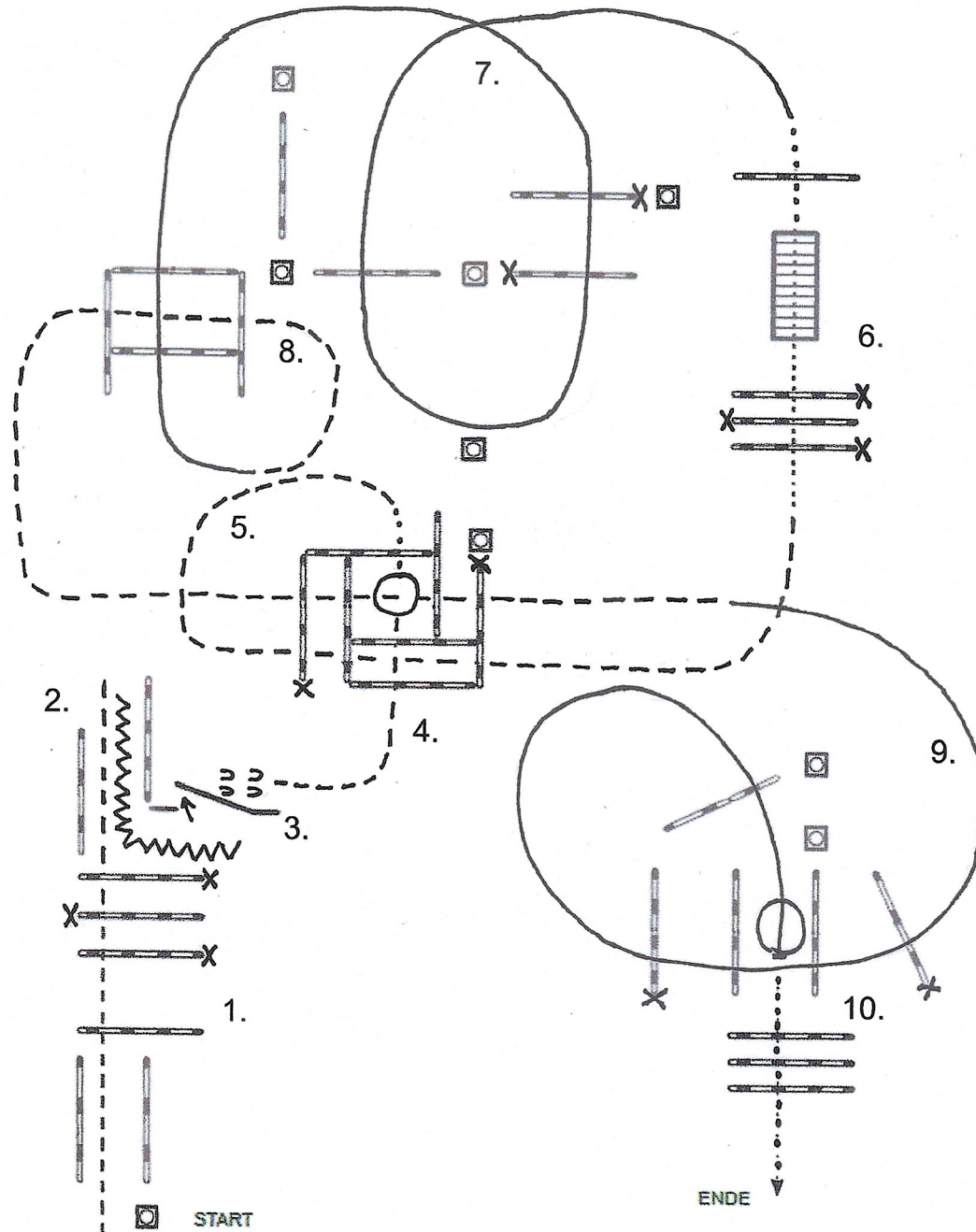

1. Trab über Stangen, stopp (Jog over, stop)
2. Rückwärts (Back Up)
3. Tor, rechte Hand (Gate, right hand)
4. Trab über Stangen in Box, stopp, Drehung 360° links, Schritt hinaus (Jog over into box, stop, turn 360° left, walk out)
5. Trab über Stangen (Jog over)
6. Schritt über Stangen und Brücke (Walk over pole and bridge)
7. Linksgalopp über Stangen (Lope over, left hand)
8. Trab über Stangen (Jog over)
9. Rechtsgalopp über Stangen, stopp (Lope over, stop)
10. Drehung 360° rechts, Schritt über Stangen (Turn 360° right, walk over)

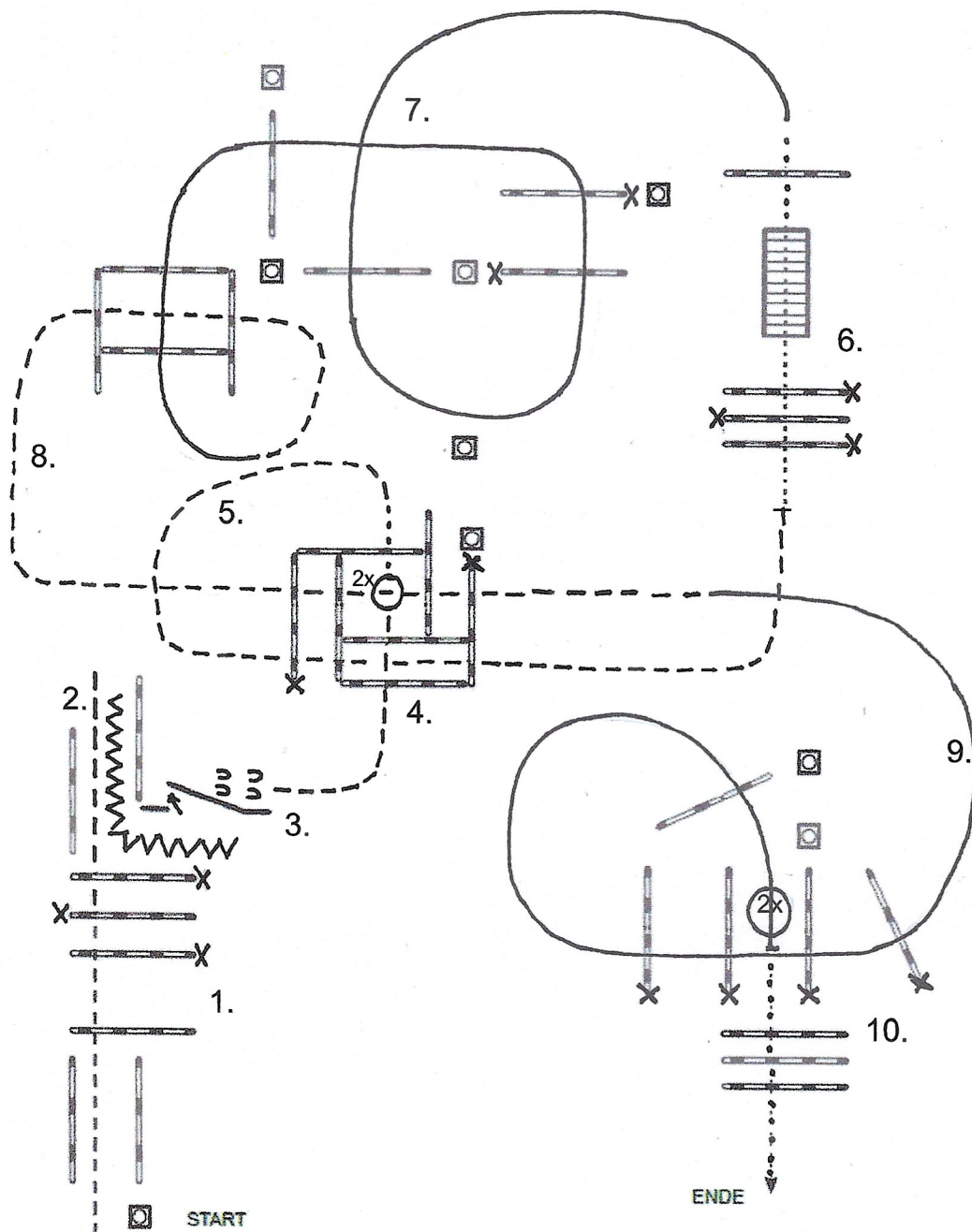

1. Trab über Stangen, stopp (Jog over, stop)
2. Rückwärts (Back Up)
3. Tor, rechte Hand (Gate, right hand)
4. Trab über Stangen in Box, Drehung 2x links, Schritt hinaus (Jog over into Box, turn 2x left, walk out)
5. Trab über Stangen, stopp (Jog over, stop)
6. Schritt über Stangen und Brücke (Walk over pole and bridge)
7. Linksgalopp über Stangen (Lope over, left hand)
8. Trab über Stangen (Jog over)
9. Rechtsgalopp über Stangen, stopp (Lope over, stop)
10. Drehung 2x rechts, Schritt über Stangen (Turn 2x right, walk over)

# Trail FÜHRZÜGEL (4-8 Jahre)

BEWERB 63

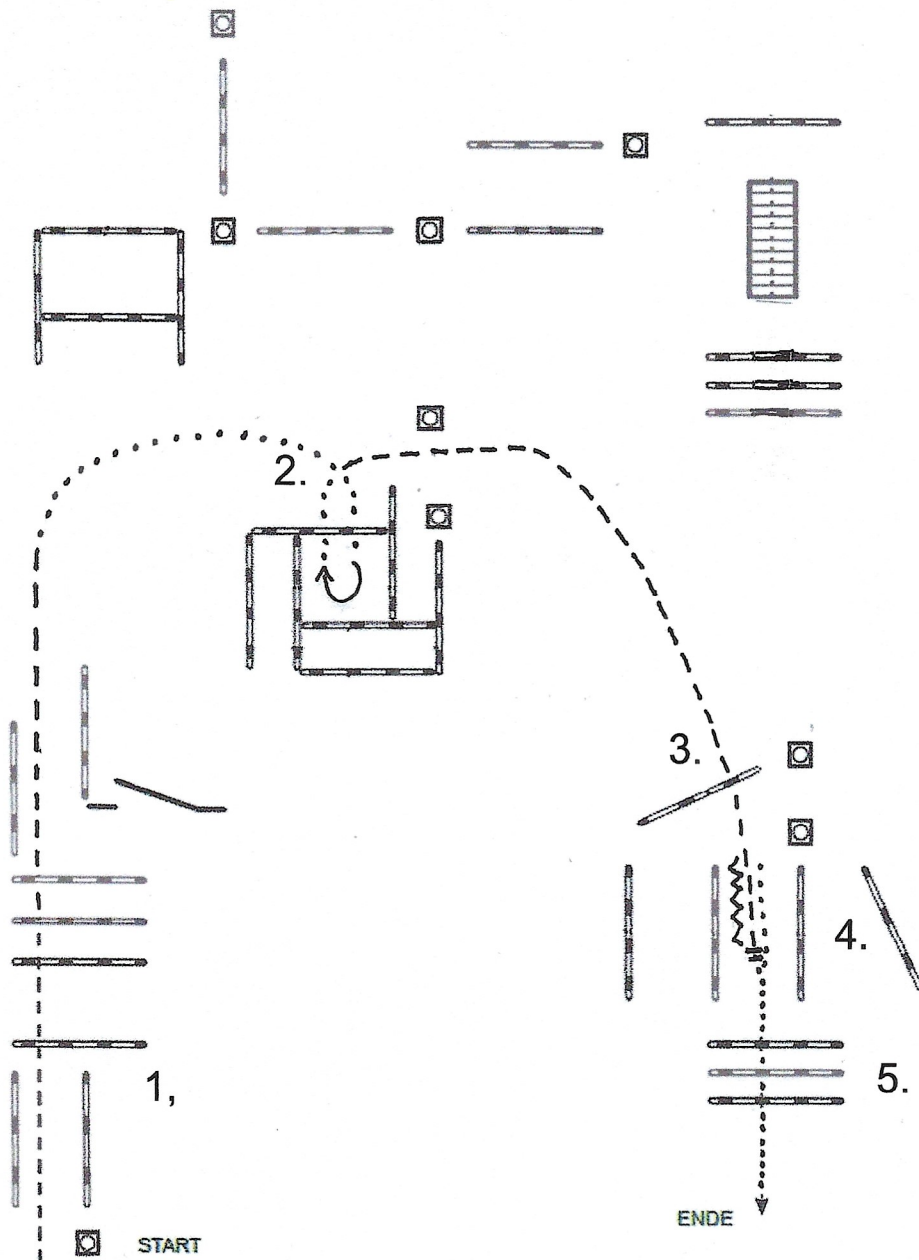

1. Trab über Stangen (Jog over)
2. Schritt in Box, 180°, Schritt hinaus (Walk into box, 180°, walk out)
3. Trab über Stange, stopp (Jog over, stop)
4. Rückwärts (Back Up)
5. Schritt über Stangen (Walk over)

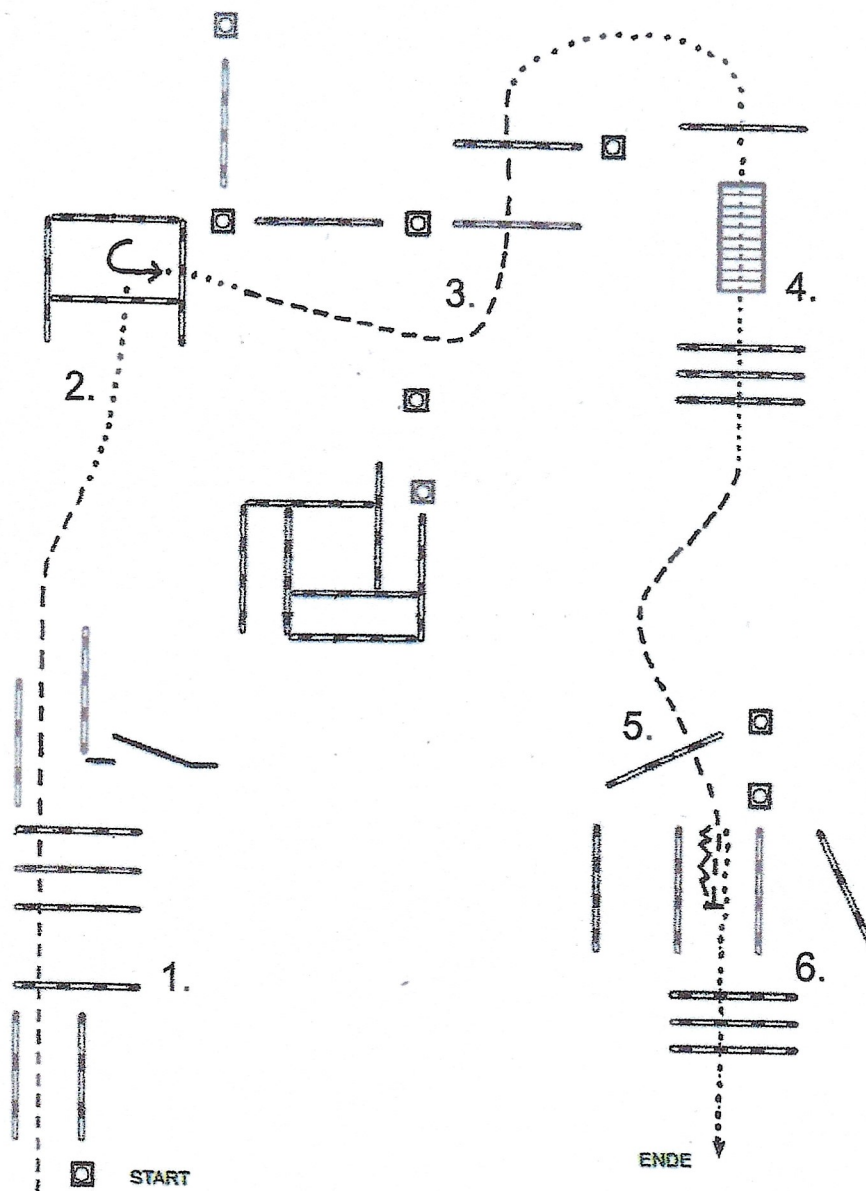

1. Trab über Stangen (Jog over)
2. Schritt in Box, 3/4 Drehung links, Schritt hinaus (Walk into box, turn 3/4 left)
3. Trab über Stangen (Jog over)
4. Schritt über Stangen und Brücke (Walk over pole and bridge)
5. Trab über Stange, stopp (Jog over, stop)
6. Rückwärts, Schritt über Stangen (Back Up, walk over)